

**oerlikon**  
hrsflow

# STARgate HRS™

It was always in front of us.  
We just had to see it differently.  
New eyes. Same world.

**Radical change.**

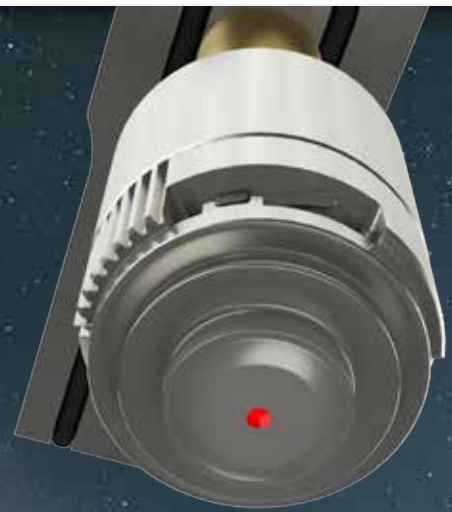

# UNLOCKING A NEW ERA IN VALVE GATE SOLUTIONS

STARgate HRS™ is a disruptive **pin-less solution** that manages the flow rate through a revolutionary **diaphragmatic design and movement**.

## Key Benefits

- **Significant cycle time reduction** thanks to the optimal cooling performance of the diaphragmatic concept
- **Pin-less design** ensures smoother plastic flow at a consistent melt speed, enabling faster color changes
- **Optimized circular flow** minimizes pressure loss for more efficient injection
- **Quick color changes** and minimized plastic waste
- **Smaller nozzle size and mold pocket** made possible by the innovative pin-less configuration
- **Simplified maintenance** with easy-to-replace gate inserts
- **Energy-saving design** with external actuator. No cooling required



Fig.1 Injection through diaphragmatic movement and design

## INSIDE TECHNOLOGY

### 1. COMPACT SOLUTION

The radical change in the actuator's position enables a **space-saving design**.

Its pin-less configuration allows for a **smaller nozzle size and mold pocket** compared to standard valve gate systems.

**STANDARD**  
Valve Gate Solution



**STARgate HRS™**



Fig.2 Actuator's position change

**STANDARD**  
Valve Gate Solution



**STARgate HRS™**



**2. PIN-LESS DESIGN**

The valve gate's position changes radically, paving the way for a pin-less design.

This ensures smoother plastic flow at a consistent melt speed, enabling **faster color changes**.

Fig.3 Valve gate's position change

**3. OPTIMAL COOLING PERFORMANCE**

The revolutionary **diaphragmatic concept** delivers optimal cooling performance. This results in a significant reduction in cycle time.

**STANDARD**  
Valve Gate Solution

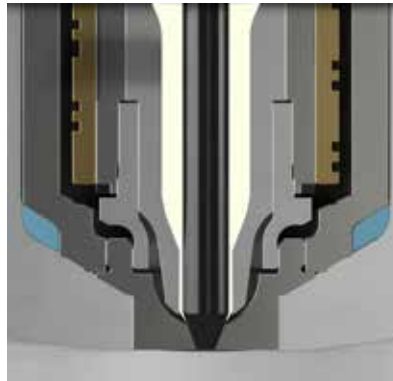

**STARgate HRS™**

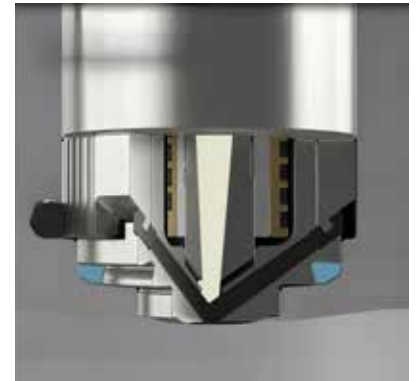

Fig.4 Cooling system's position change

# >> Best Practice

## Turning innovation into results

### HOT RUNNER SYSTEM FEATURES

Molding material:	PP (Post-Consumer Recycled, MFR40)
Cavities N°:	2
System type:	STARgate HRS™ Technology, 2 drops, M series



### PART DESCRIPTION

Application:	Bucket
Sector:	Thin Wall Packaging
Part dimensions:	6.6 liter
Part weight:	200 g
Part thickness:	1.1 mm
Cycle time	6.2 s

### HIGHLIGHTS

- Significant cycle time reduction
- Pin-less design
- Space saving solution
- Lower pressure loss
- Faster colour change

**Oerlikon HRSflow Italy**

Headquarter and Production Plant  
INGlass S.p.a.  
Via Piave, 4 - San Polo di Piave  
31020 Treviso  
Phone +39 0422 750 111  
info.hrsflow@oerlikon.com - www.hrsflow.com

**24/7 Service Hotline**

Phone +39 0422 750 555  
service.hrsflow@oerlikon.com

**Oerlikon HRSflow China**

Production Plant  
INGlass Tooling & Hot Runner Manufacturing  
(China) Co. Ltd  
No. 385, Road No. 18, Xiasha, Hangzhou Econ. &  
Tech. Devel. Area Zhejiang 310018  
Phone +86 571 86686900  
china.hrsflow@oerlikon.com

**24/7 customer service for Asian countries**

Phone +86 18858181211  
service.china.hrsflow@oerlikon.com

**Oerlikon HRSflow USA**

Production Plant  
Oerlikon HRSflow USA, LLC  
920 74th Street - 49315 Byron Center, MI  
Phone +1 616 228 6900  
usa.hrsflow@oerlikon.com

**24/7 Service Hotline**

Phone +1-855-HRS-FLOW (1-855-477-3569)  
service.usa.hrsflow@oerlikon.com

---

Production and development planning/engineering by INglass Spa.

The trademarks of INGLASS S.p.A. referred to in this document are the exclusive property of the company. Any other trademarks or logos of third parties belong to their respective owners. The symbols ® and ™ are used in this material for INGLASS S.p.A. trademarks solely for global informational purposes; such trademarks are registered or filed only in certain jurisdictions, therefore the presence of the ® symbol may not constitute evidence of the trademark's registration in the specific country where this material is viewed or distributed. To consult the updated list of trademarks and the relevant territories of protection, please visit [Trademarks](#) or contact info.hrsflow@oerlikon.com.

INGlass Spa portfolio includes more than three hundred patent applications and granted patents worldwide. Granted patents are listed on web page [Italy\\_patents\\_2026 copy](#). INGlass Spa products may be covered by one or more of these patents and patent applications.