

oerlikon
hrsflow

STARgate HRS

It was always in front of us.
We just had to see it differently.
New eyes. Same world.
Radical change.

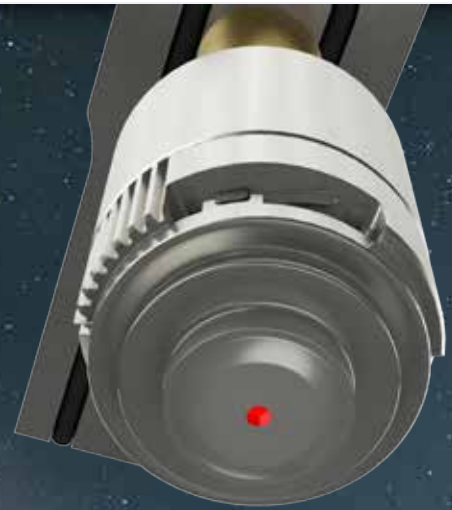

UNLOCKING A NEW ERA IN VALVE GATE SOLUTIONS

STARgate HRS® is a disruptive **pin-less solution** that manages the flow rate through a revolutionary **diaphragmatic design and movement**.

Key Benefits

- **Significant cycle time reduction** thanks to the optimal cooling performance of the diaphragmatic concept
- **Pin-less design** ensures smoother plastic flow at a consistent melt speed, enabling faster color changes
- **Optimized circular flow** minimizes pressure loss for more efficient injection
- **Quick color changes** and minimized plastic waste
- **Smaller nozzle size and mold pocket** made possible by the innovative pin-less configuration
- **Simplified maintenance** with easy-to-replace gate inserts
- **Energy-saving design** with external actuator. No cooling required



Fig.1 Adjustable flow rate through diaphragmatic movement and design

INSIDE TECHNOLOGY

1. COMPACT SOLUTION

The radical change in the actuator's position enables a **space-saving design**.

Its pin-less configuration allows for a **smaller nozzle size and mold pocket** compared to standard valve gate systems.

STANDARD
Valve Gate Solution



STARgate HRS®



Fig.2 Actuator's position change

STANDARD
Valve Gate Solution



STARgate HRS®



2. PIN-LESS DESIGN

The valve gate's position changes radically, paving the way for a pin-less design.

This ensures smoother plastic flow at a consistent melt speed, enabling **faster color changes**.

Fig.3 Valve gate's position change

3. OPTIMAL COOLING PERFORMANCE

The revolutionary **diaphragmatic concept** delivers optimal cooling performance. This results in a significant reduction in cycle time.

STANDARD
Valve Gate Solution

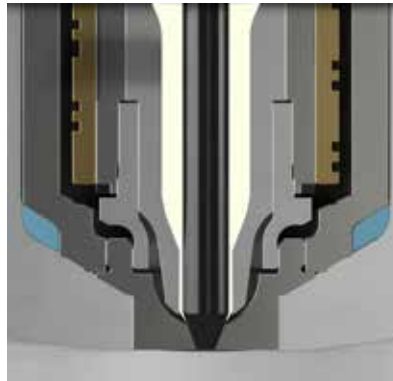

STARgate HRS®

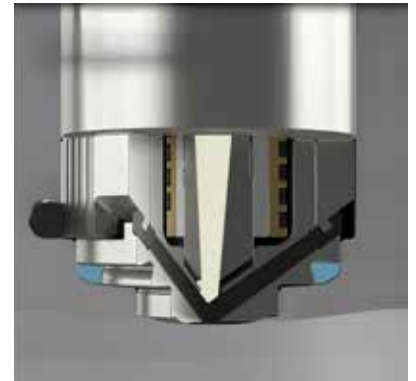

Fig.4 Cooling system's position change

>> Best Practice

Turning innovation into results

HOT RUNNER SYSTEM FEATURES

Molding material:	PP (Post-Consumer Recycled, MFR40)
Cavities N°:	2
System type:	STARgate HRS Technology, 2 drops, M series

PART DESCRIPTION

Application:	Bucket
Sector:	Thin Wall Packaging
Part dimensions:	6.6 liter
Part weight:	200 g
Part thickness:	1.1 mm
Cycle time	6.2 s



HIGHLIGHTS

- Significant cycle time reduction
- Pin-less design
- Space saving solution
- Lower pressure loss
- Faster colour change

Oerlikon HRSflow Italy

Production Plant
Headquarter
Via Piave, 4 - San Polo di Piave
31020 Treviso
Phone +39 0422 750 111
info.hrsflow@oerlikon.com - www.hrsflow.com

24/7 Service Hotline

Phone +39 0422 750 555
service.hrsflow@oerlikon.com

Oerlikon HRSflow China

Production Plant
InGlass Tooling & Hot Runner Manufacturing
(China) Co. Ltd
No. 385, Road No. 18, Xiasha, Hangzhou Econ. &
Tech. Devel. Area Zhejiang 310018
Phone +86 571 86686900
china.hrsflow@oerlikon.com

24/7 customer service for Asian countries

Phone +86 18858181211
service.china.hrsflow@oerlikon.com

Oerlikon HRSflow USA

Production Plant
Oerlikon HRSflow USA, LLC
920 74th Street - 49315 Byron Center, MI
Phone +1 616 228 6900
usa.hrsflow@oerlikon.com

24/7 Service Hotline

Phone +1-855-HRS-FLOW (1-855-477-3569)
service.usa.hrsflow@oerlikon.com