

# TAPERED NOZZLE: FURTHER APPLICATION EXAMPLE

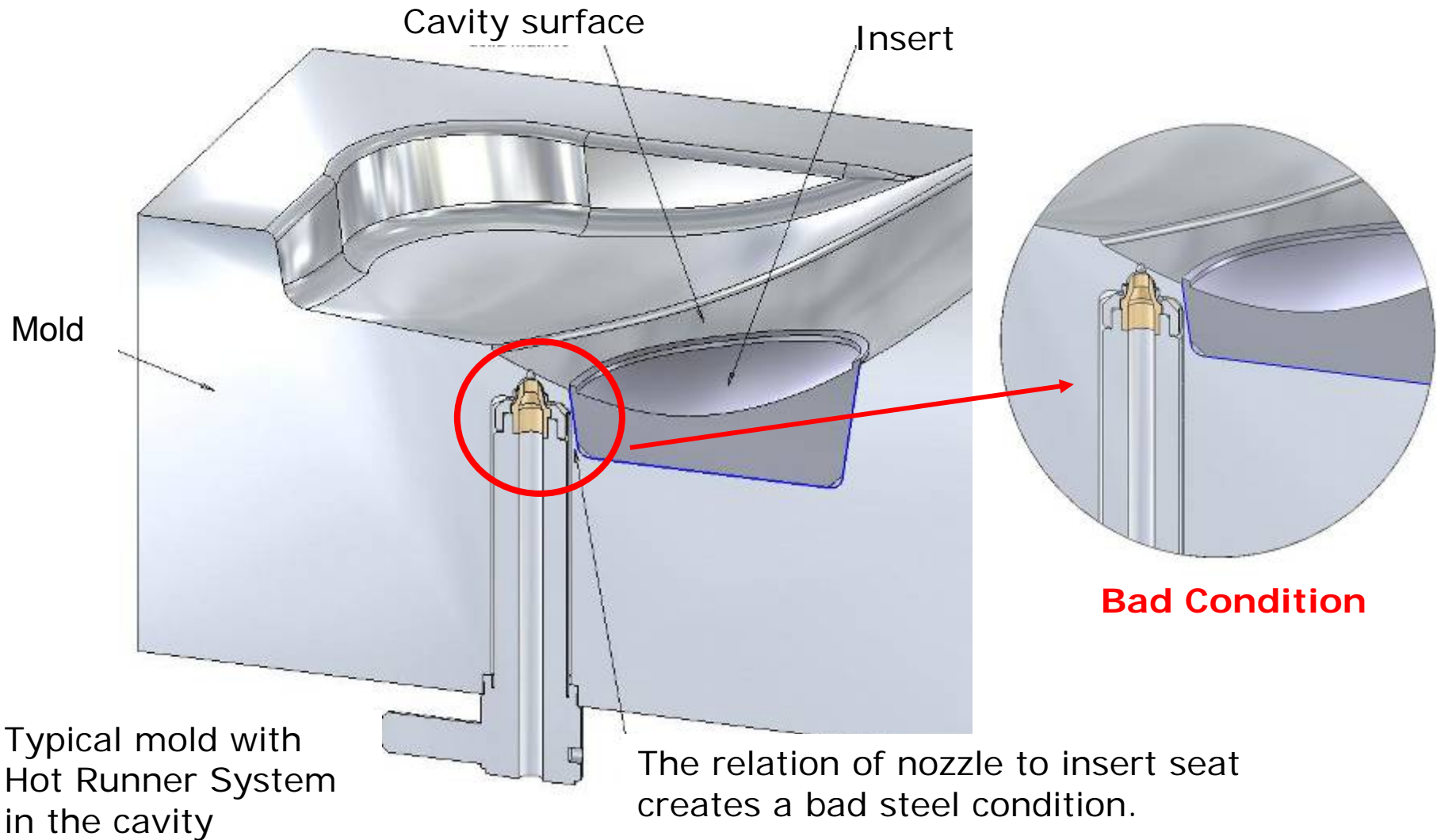

# USUAL SOLUTION WITHOUT TAPERED NOZZLE

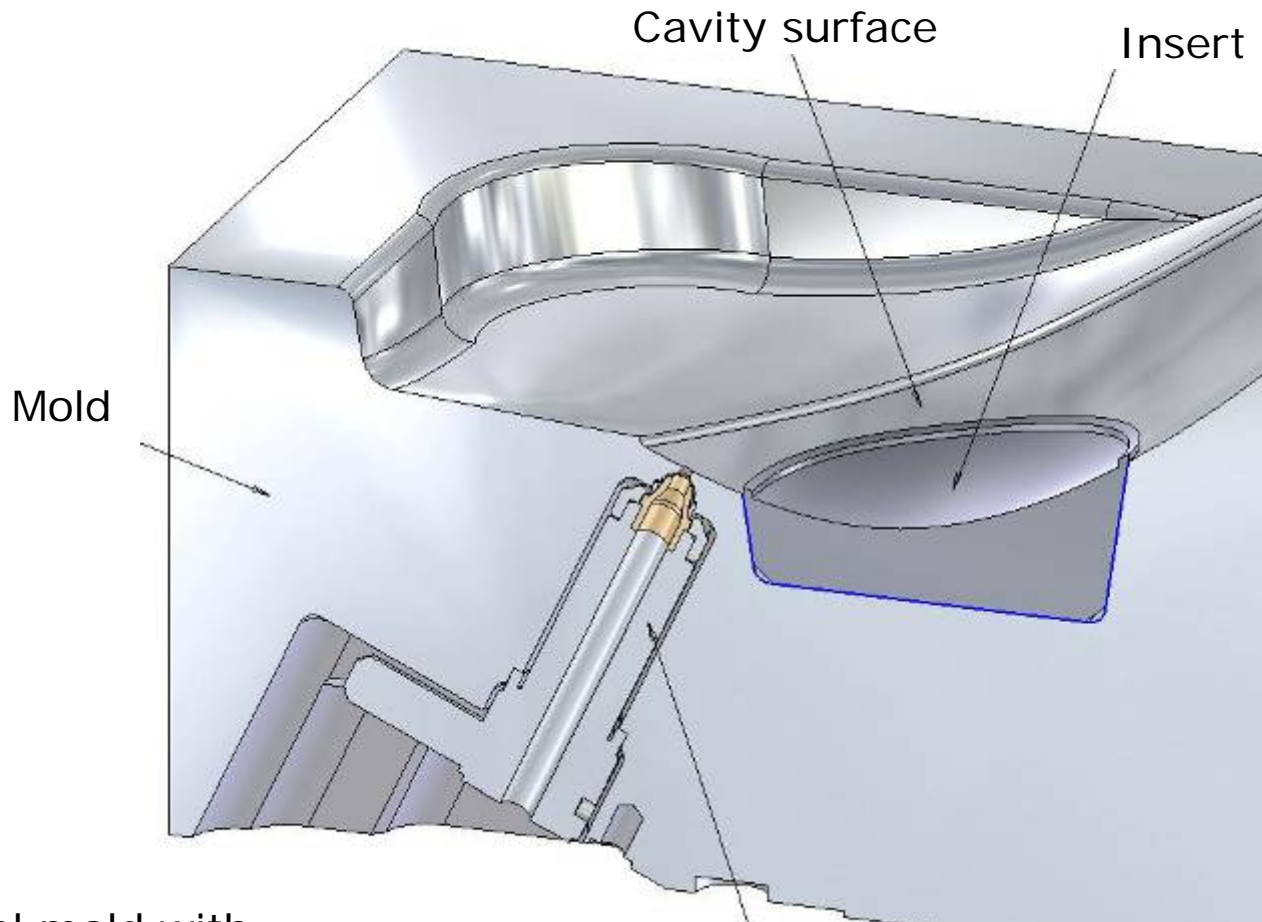

Typical mold with  
Hot Runner System in  
the cavity

The nozzle must be angled to avoid the bad  
condition around the insert. This cost more  
money (Machining, Manifold, Time)

# USE OF THE TAPERED NOZZLE

Cavity Surface

Insert

Mold

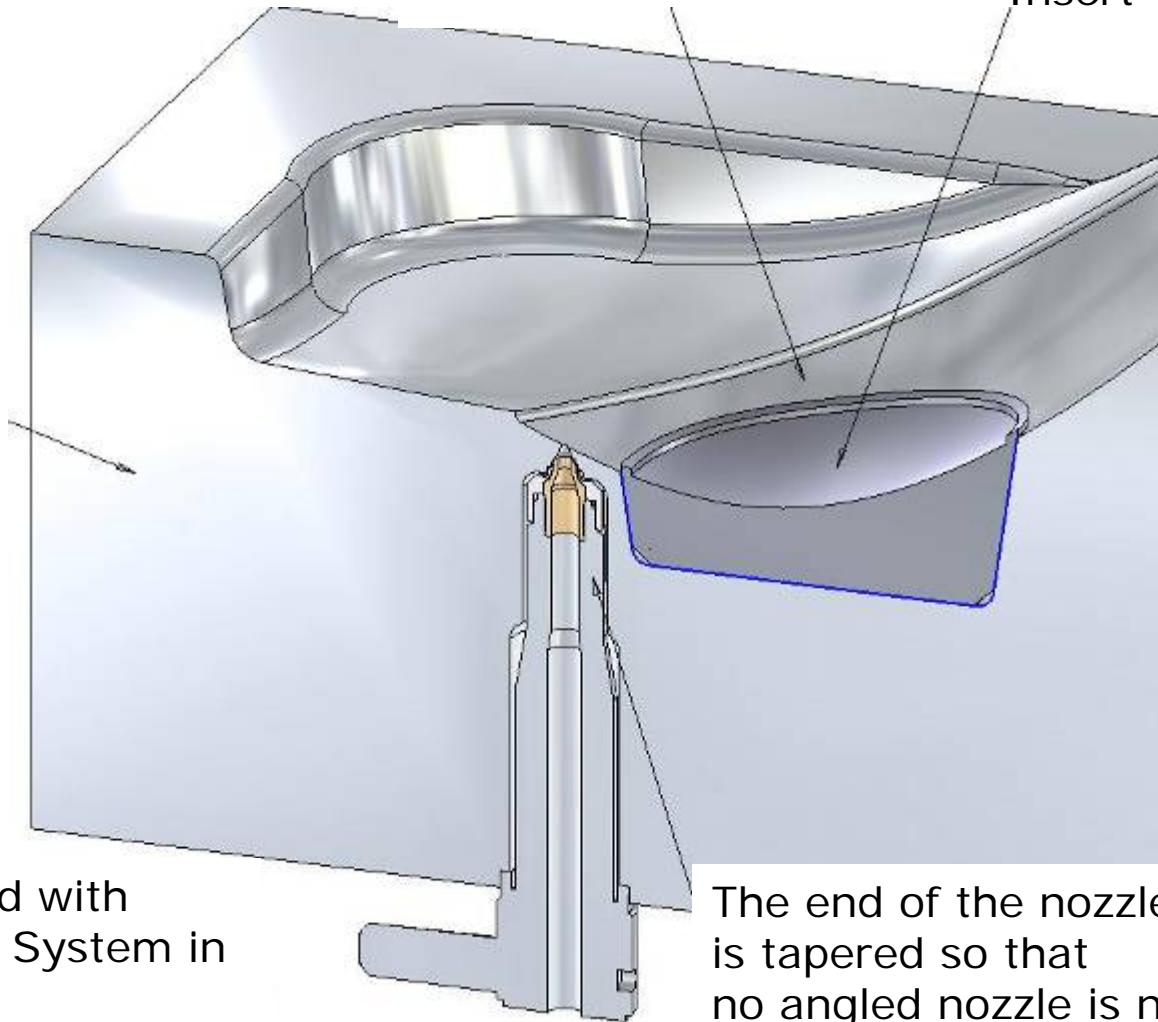

Typical mold with  
Hot Runner System in  
the cavity

The end of the nozzle  
is tapered so that  
no angled nozzle is needed